

Trunk 2000® Fume Collector

Model T-2000

A self-contained source collector designed to capture fume generated from moderate-to-heavy welding applications.



T-2000

- Designed to handle one or two welding stations using Flex-Trunk® arms.
- Ceiling-mount configuration saves valuable plant floor space and provides optimum range of the flex arms.
- FLUENT™ designed inlet and dust hopper minimize fume re-entrainment and reduce maintenance expense.
- Automatic pulse-cleaning system for continuous welding operations.
- Patented filter cleaning system lengthens filter life.
- Ultra-Web® FR filter cartridges featuring nanofiber technology provide high filtration efficiency and long filter life.
- MERV* 13 filtration efficiency rating outperforms the competition.
- Recirculation of clean air reduces need for costly make-up air.

Trunk 2000® Collector

Dimensions & Specifications

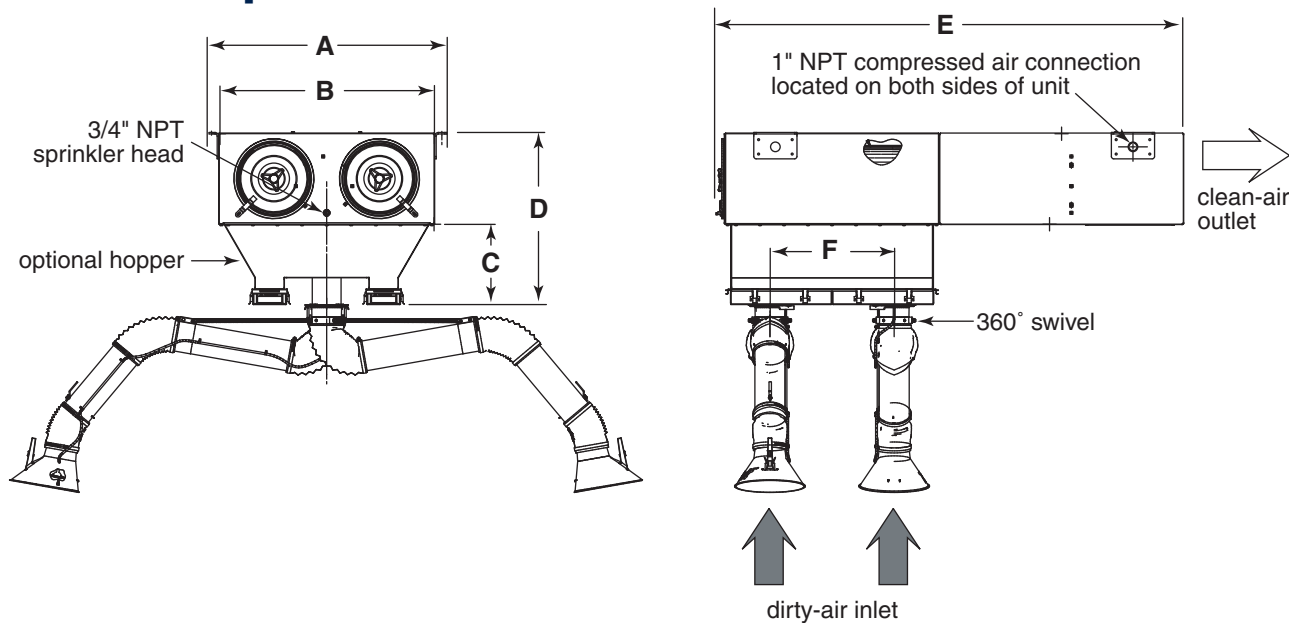

Model	Nominal Airflow** (cfm)	No. of Filters (Ultra-Web FR)	Filter Area (ft²)	No. of 3/4" Valves	Dimensions (in)						Shipping Weight (lbs)	Sound Level dB(A)†	
					A	B	C	D	E	F		Fan	Pulse
T-2000	890	4	636	2	50.0	45.0	16.9	35.9	97.4	25.9	790	71	80.5

Standard Features

- Ultra-Web® FR cartridges
- 5 hp TEFC motor
- One (1) Flex-Trunk® extraction arm with light
- Sprinkler head
- 110 VAC control box
208/230/460/60/3 voltage
- 10-year warranty

Equipment Options

- Flex-Trunk or Flex-Trunk Plus extraction arms - 7', 8', 9', 10', 12' 14'
- Magnehelic® gauge
- Photohelic® gauge
- Hopper with re-entrainment baffles and four removal dust pans
- Solenoid valve silencer

* The Minimum Efficiency Reporting Value (MERV) of this filter cartridge has been determined through independent laboratory testing using ASHRAE 52.2 (1999) test standards. The MERV rating was determined at a face velocity of 118 feet per minute and loading up to four inches water gauge. Actual efficiency of any filter cartridge will vary according to the specific application parameters. Dust concentration, airflow, particle characteristics, and pulse cleaning methods all affect filtration efficiency.

** Based on clean filters, per Flex-Trunk/Flex-Trunk Plus.

† db(A) sound levels are an average of measurements made in a laboratory environment. Installed sound levels will vary depending on the measurement location, operating conditions, and installation.

™ FLUENT is a trademark of Fluent, Inc.

® Magnehelic and Photohelic are registered trademarks of Dwyer Instruments, Inc.



Donaldson Company, Inc.
Industrial Air Filtration
P.O. Box 1299
Minneapolis, MN 55440

Tel 800-365-1331(USA)
Tel 800-343-3639 (within Mexico)
dustmktg@mail.donaldson.com
www.donaldsoncorp.com



Information in this document is subject to change without notice.

© 1999 Donaldson Co., Inc.
Printed in U.S.A. on recycled paper
Data Sheet T-2000 (06/05)